

# **TABLE of CONTENTS**

## **SS<sup>Plus</sup> SPECIFICATION**

<b>Section</b>	<b>Description</b>	<b>Page No.</b>
1.0	Introduction	1
2.0	Applicable Standards, Codes and Regulations	1
3.0	Environmental Conditions	1
4.0	System Description	2
5.0	System Operation	2
	5.1 Normal	2
	5.2 Low DC Disconnect	2
	5.3 Bypass	2
	5.4 Load Transfer	3
	5.5 Manual Bypass	3
	5.6 System Start-Up	3
	5.7 System Shut-Down	3
6.0	Static Inverter	4
	6.1 General	4
	6.2 Output Voltage	4
	6.3 Input Voltage	4
	6.4 Voltage Regulation	4
	6.5 Frequency Regulation	4
	6.6 Frequency Control	5
	6.6 Load Power Factor	5
	6.8 Harmonic Distortion	5
	6.9 Crest Factor	5
	6.10 Slew Rate	5
	6.11 AC Transient Response	5
	6.12 AC Transient Recovery	5
	6.13 Overload Capability	5
	6.14 Over Temperature	6
	6.15 DC Input Transient	6

7.0	Static Transfer Switch	6
	7.1 General	6
	7.2 Operation	6
	7.3 Transfer Time	7
	7.4 Transfer Point	7
	7.5 Auto-Transfer Defeat	7
	7.6 Fail-Safe Design	7
	7.7 Overload Rating	7
8.0	Manual Bypass Switch	7
	8.1 Mounting	8
	8.2 Configuration	8
	8.3 Overload Rating	8
9.0	Accessories	8
	9.1 Controls	8
	9.2 Meters	8
	9.3 Mimic Panel/Indicator Lights and Alarms	9
	9.4 Optional Indicators and Alarms	10
	9.5 Optional Serial Communications Port	12
	9.6 Overload Protection	13
10.0	General Requirements	14
	10.1 System Efficiency	14
	10.2 Audible Noise	14
	10.3 Cooling	14
	10.4 Wiring	14
	10.5 EMI Suppression	15
	10.6 Control Power Supply	15
	10.7 Transformers	15
	10.8 Nameplate Markings	15
11.0	Mechanical Specification	15
	11.1 Enclosure	15
	11.2 Ventilation	16
	11.3 Cable Entry	16
	11.4 Power Connections	16
	11.5 Parts Placement	16
	11.6 Wire Supports	17
	11.7 Wire Marking	17
	11.8 Component Marking	17
	11.9 Personnel Safety	17
	11.10 Painted Surfaces	17

12.0	Shop Testing	17
13.0	Documentation	17
	13.1 Outline Drawings	17
	13.2 Schematic Drawings	18
14.0	Preparation for Shipment	18

## **1.0 INTRODUCTION**

This specification describes a continuous duty, solid-state, on-line inverter. This means that under normal conditions, power is provided to the load through the inverter. Incoming DC power from a Rectifier/Battery Charger or station battery is converted to clean, conditioned AC power. The inverter shall operate in conjunction with the existing building/plant electrical systems to provide high quality power to the critical load. The Inverter system shall consist of an integrated Inverter bridge, Constant Voltage Transformer (CVT), Static Transfer Switch, and Manual Maintenance Bypass Switch.

## **2.0 APPLICABLE STANDARDS, CODES AND REGULATIONS**

Unless noted otherwise, the design, fabrication, testing, and performance of the system shall be in accordance with the latest revisions of the following industry/agency standards and codes, where applicable:

National Electrical Manufacturers Association (NEMA)  
American National Standards Institute (ANSI)  
National Electric Code (ANSI/NFPA 70)  
Institute of Electrical and Electronic Engineers (IEEE)  
International Electrotechnical Commission (IEC)  
UL 1778 (C-UL)

## **3.0 ENVIRONMENTAL CONDITIONS**

### **3.1 Operating Temperature**

The system shall operate at rated output without any adverse affects in an ambient temperature of 0°C to 40°C (32°F to 104°F), except batteries.

### **3.2 Relative Humidity**

The system shall operate at a relative humidity of 5% to 95%, non-condensing, for a temperature range of 10°C to 40°C (32°F to 104°F).

### **3.3 Operating Altitude**

The system shall operate at any altitude from sea level up to 2500m Meters ( 8,200ft) above sea level without de-rating.

## **4.0 SYSTEM DESCRIPTION**

Each inverter system, as a minimum, shall consist of the following major components:

- Static Inverter (Single Phase Output)
- Static Transfer Switch (Zero break)
- Manual Bypass Switch (Electro-Mechanical; Make-Before-Break)
- Battery Bank

## **5.0 SYSTEM OPERATION**

### **5.1 Normal**

The critical load is continuously supplied by the inverter, with isolated, regulated AC voltage. The inverter output shall be in phase with the bypass source.

If the bypass source deviates more than +/-0.5% of (50 or 60 HZ) the inverter output shall run on its own internal oscillator until the reference source returns to within acceptable limits.

### **5.2 Low DC Disconnect**

When the battery voltage reaches 105 VDC for 5 seconds, the system shall automatically transfer the load to bypass and disconnect the battery via a shunt trip in the breaker to prevent damage to the batteries.

### **5.3 Bypass**

During an overload or load fault at the inverter output, the static switch shall automatically transfer the load to commercial power (transfer point factory set @ 120% of rated load) without interruption.

On clearing an inverter malfunction, fault or overload condition, the static transfer switch shall automatically transfer the U.P.S. load from the bypass to the inverter output. The transfer from both directions shall be without interruption (zero-break). A static switch transfer can only be accomplished when the inverter output is in sync with the bypass source. (except during inverter failure)

Transfer to the bypass may also be accomplished manually by the Bypass to Load push button without interruption. This shall lock out the auto retransfer function.

Upon the deterioration or failure of the inverter bridge output, the load shall be transferred to bypass without any interruption.

## 5.4 Load Transfer

Pressing the Bypass to Load push button while the inverter is supplying the load, the static switch shall transfer the load to the bypass source if the bypass source is available and it is in sync with the inverter. The operation of the Inverter to Load push button is the same as the Bypass to Load push button except it transfers the load to the inverter.

## 5.5 Manual Bypass

During maintenance the system may be bypassed, without interruption to the load, for ease of inspection.

## 5.6 System Start-Up

- Press the pre-charge button (provided on units 20 kVA and larger) until the pre-charge LED is lit.
- Close the Bypass Source AC Circuit Breaker.

As soon as the inverter output is synchronized with the bypass source, the “In-Sync” LED will light. (Note: If the Auto-Retransfer switch is in the “ON” position, the static switch will automatically transfer the load onto the inverter).

- Verify that the static switch is in the “Bypass To Load” position, and transfer the manual bypass switch to the “NORMAL” position.
- Press ‘Inverter To Load’ pushbutton.

*The inverter is now supplying clean, uninterrupted power to the load.*

## 5.7 System Shut-Down

- Press ‘Bypass To Load’ pushbutton.
- Transfer manual bypass switch to the “Bypass To Load” position.
- Open Bypass Source AC Circuit Breaker

*The load is now being powered by the alternate (or bypass) AC source via the Manual Switch.*

## **6.0 STATIC INVERTER**

### **6.1 General**

The static inverter shall be a ferroresonant type, which generates single-phase AC power. The inverter shall be capable of providing continuous and uninterruptible output power while operating from any DC source within the operating input range.

The inverter bridge shall use power transistors, and Insulated Gate Bipolar Transistors, (IGBTs) to generate the square wave input for the ferroresonant transformer.

### **6.2 Output Voltage**

The inverter's output circuit shall be magnetically isolated from the input circuit and be supplied with a convenient means of grounding or ungrounding the inverter's output.

The inverter's output voltage shall be single phase as specified in the System Data Sheet.

The inverter's output voltage shall be maintained for at least 1/2 cycle during an input bridge failure to insure a zero-break static transfer to the bypass source. The inverter's output voltages shall be supplied in standard (50 or 60) Hz values

### **6.3 Input Voltage**

The maximum DC input voltage shall range from 105-144 VDC while maintaining the specified output voltage.

### **6.4 Voltage Regulation**

The inverter steady state output voltage regulation shall not change more than +/-2% under any of the following conditions:

1. 10% to 100% and 100% to 10% load change.
2. Minimum to maximum DC bus voltage.

### **6.5 Frequency Regulation**

The free-running, steady state output frequency of the Inverter shall not deviate more than 0.1% due to the following conditions;

1. 10% to 100% load
2. Minimum to maximum ambient temperature
3. Minimum to maximum DC bus voltage

## **6.6 Frequency Control**

The output frequency of the inverter shall be controlled by a crystal controlled oscillator, which can be operated as a free-running unit or as a slave for synchronized operation with a separate AC source. The inverter shall track the AC reference source provided it is (50) (60) +/-0.5% HZ. Upon failure or excessive frequency deviation of the reference the oscillator shall automatically revert to its free-running mode.

## **6.7 Load Power Factor**

The inverter shall be capable of handling linear loads of 0.8 pf -1.0 pf while maintaining +/-2% regulation and non- linear loads (switch-mode power supplies) with a power factor range of 0.7 to 1.0. All testing and verification shall be conducted with a Harmonic, rather than Displacement PF type load.

## **6.8 Harmonic Distortion**

The inverter shall limit the total harmonic distortion of the output voltage to less than 5% RMS total with a 100% linear load or less than 7.5% THD with a 100% switch-mode type load.

## **6.9 Crest Factor**

The inverter shall be capable of supplying non-linear loads exhibiting a crest factor of up to 3.0 at full load without additional filtering or increasing the size of the system.

## **6.10 Slew Rate**

The inverter frequency rate of change shall not exceed 1 Hz/second when synchronizing to the bypass reference.

## **6.11 AC Transient Response**

The inverter voltage transient response shall not exceed +8% to -10% due to a 100%-50% or 50%-100% step load change. During a 100% step load the maximum deviation shall be 23% for the first half cycle.

## **6.12 AC Transient Recovery**

The output voltage, following the step load changes listed above, shall return to within +/-2% of the steady state output voltage within 50 msec (60Hz units).

### **6.13 Overload Capability**

The inverter shall be capable of supplying loads up to 120% of the rated load for 10 minutes without transfer to the bypass. The inverter shall current limit at approximately 175% and supply up to 500% rated current for approximately one cycle.

### **6.14 Over Temperature**

Upon heat sink over temperature, the U.P.S. shall automatically transfer the load to the bypass source. If the over temperature occurs for more than 60 seconds, the DC/battery input breaker shall trip protecting the bridge from damage. Manual retransfer of the load onto the inverter shall be permitted when the temperature returns to normal.

### **6.15 DC Input Transient**

The DC input shall include an input filter to suppress externally generated DC transients and to control inverter switching transients at the battery. Filtering shall be designed to suppress a transient of 4000 volts, with a 10 micro second duration, occurring at the inverters DC input terminals.

## **7.0 STATIC TRANSFER SWITCH**

### **7.1 General**

The static switch shall be a naturally commutated, high-speed transfer device provided as an integral part of the U.P.S. The control of the unit shall provide an automatic or manual uninterrupted transfer of the load to the bypass.

The static switch shall use inverse parallel connected 600 volt silicon controlled rectifiers with an ampacity suitable to carry ten times the inverter's capacity for one cycle.

### **7.2 Operation**

The static switch shall automatically connect the bypass source to the critical load and have the following features.

**Uninterrupted Transfer** - The static switch shall automatically transfer the critical load after the control logic senses one of the following conditions:

1. Inverter Failure
2. Inverter Overcurrent
3. Inverter Output Over/Under Voltage (+/-10%) >16 msec.
4. Low DC Disconnect
5. Manual Transfer via front panel push button

**Uninterrupted Automatic Retransfer** - If the transfer control switch is set for automatic retransfer, the control circuit shall be capable of retransferring the critical load to the inverter output when the overload is removed and the inverter output is within specification.

**Uninterrupted Manual Retransfer** - If the transfer control switch is set for manual retransfer, upon manual command the critical load shall be transferred to the inverter.

**Transfer Lockout** - The transfer logic shall not allow a transfer to the bypass source if one of the following conditions exist:

1. Bypass source out of sync with inverter output (Except for upon inverter failure or low DC disconnect.)
2. Bypass source not available

### **7.3 Transfer Time**

The transfer time of the static switch shall be zero, resulting in an uninterrupted flow of power to the system loads.

### **7.4 Transfer Point**

The static switch current sense transfer point shall be adjustable from 100% to 125%, factory set at 120%

The current sense shall be designed to prevent premature switching of the static switch with high crest factor loads.

### **7.5 Auto-retransfer Defeat**

An internal switch shall be provided to defeat the automatic retransfer of the static switch after a transfer to the bypass source. Shipment setting for the unit shall be OFF (i.e. auto-retransfer not activated).

### **7.6 Fail-Safe Design**

The static switch shall be designed to fail over to the bypass source. An independent watchdog circuit shall be provided to insure static switch transfer to bypass upon microprocessor failure.

### **7.7 Overload Rating**

The static switch shall be rated for continuous operation at 125% of full rated load; 1000% for one (1) cycle.

## **8.0 MANUAL BYPASS SWITCH**

A manually operated mechanical bypass switch shall be provided to facilitate system maintenance. In the bypass position, this switch and the static switch input breaker shall isolate the static switch from the bypass source and connect the output directly to the bypass power source.

### **8.1 Mounting**

The manual bypass switch shall be mounted in the system enclosure to reduce interconnect wiring. (As an option, a remote-mounted 3-position switch shall be available.)

### **8.2 Configuration**

The manual bypass switch shall be of a "make-before-break" configuration to ensure absolute continuity of AC power to the critical U.P.S. loads during switch over.

The manual bypass switch shall not require the assistance of the static switch to insure a zero break load transfer.

### **8.3 Overload Rating**

The manual bypass switch shall be rated for continuous operation at 125% of full rated load; 1000% for one (1) cycle.

## **9.0 ACCESSORIES**

### **9.1 Controls**

All controls specified below shall be accessible on the front panel unless otherwise noted.

#### **9.1.1 Inverter to Load**

A lighted momentary push button shall be provided to transfer the load to the inverter source.

#### **9.1.2 Bypass to Load**

A lighted momentary push button shall be provided to transfer the load to the bypass source.

#### **9.1.3 Pre-Charge**

DC filter capacitors on 20 kVA inverters and larger shall include a current limited pre-charge circuit, activated by a pushbutton on the front panel of the inverter.

## 9.2 Meters

At a minimum the front panel shall be equipped with the following 3.5 inch scale analog meters (2% accuracy) for the following functions:

- Inverter Output Voltmeter
- AC Output Ammeter
- Inverter Output Frequency Meter (expanded scale)

### 9.2.1 Optional Meters

Other, *optional* meters shall be available, to include:

- System Output Voltmeter
- Bypass Source Input Voltmeter
- Bypass Frequency Meter
- DC Input Voltmeter
- DC Input Ammeter

## 9.3 Mimic Panel/Indicator Lights and Alarms

The system shall be equipped with an operational (lighted) mimic panel (See Figure 1.0), displaying the following LEDs. A form 'C' contact (SPDT) rated 3 amps @120VAC/28VDC shall be furnished for each specified alarm.

### 9.3.1 Battery Supplying Load

An indicator (Red) and alarm contact shall be provided to indicate when the battery is supplying power to the load through the inverter (DC bus voltage <127 VDC). The relay shall be normally energized.

### 9.3.2 Bypass Source Failure

An indicator (Red) and alarm contact shall be provided to indicate when the bypass source has failed. The relay shall be normally energized.

### 9.3.3 Inverter Supplying Load

An indicator (Amber) shall be provided to indicate when the load is being powered by the inverter.

### 9.3.4 Fan Failure

An indicator (Red) and alarm contact shall be provided when any fan has failed. The relay shall be normally de-energized.

### 9.3.5 In Sync

An indicator (Green) shall be provided when the internal oscillator of the inverter is synchronized to a bypass reference source that is within +/- 0.5 Hz of 60 (or 50) Hz.

### 9.3.6 Static Switch Transfer

An alarm contact (no LED) shall be provided to sense when the inverter is supplying power to the load. The relay shall be normally energized.

### 9.3.7 Static Switch Position

LED indicators (w/o alarm contacts) shall be supplied to indicate the position of the static switch.

### 9.3.8 Pre-Charge

An indicator for inverter pre-charge shall be supplied on inverter sizes 20 kVA and larger.

### 9.3.9 Low DC Disconnect

An indicator (Red) and alarm shall be provided to indicate when the DC input breaker has been tripped due to DC disconnect caused by the battery reaching its end of discharge voltage level.

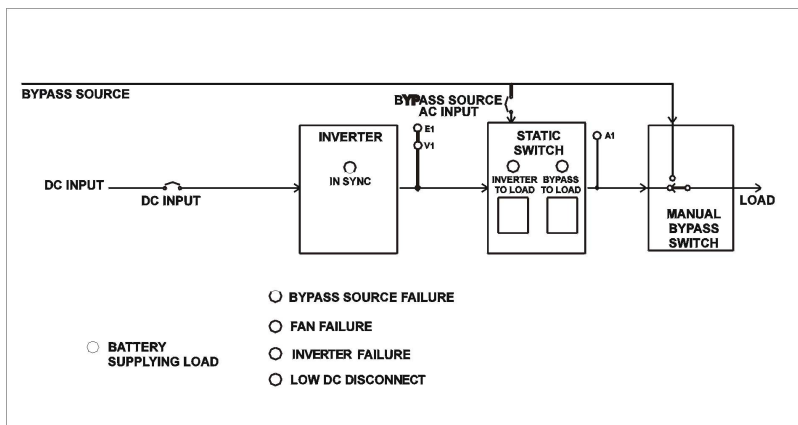

Figure 1.0 Mimic Panel/One-Line Diagram

## 9.4 Optional Indicating Lights and Alarms

The following **Optional** Indicating lights shall be provided on the mimic panel, when required; total number not to exceed the physical limitations of the mimic panel.

#### **9.4.1 High DC Voltage**

An indicator (Red) and alarm shall be provided when the inverter DC input voltage is greater than 144 VDC. The relay shall be normally de-energized.

#### **9.4.2 High DC Disconnect**

An indicator (Red) and alarm shall be provided when the DC Input Breaker has tripped due to High DC Disconnect (DC bus voltage > 145 VDC for 5 seconds). The relay shall be normally de-energized.

#### **9.4.3 Negative to Ground**

An indicator (Red) and alarm shall be provided when the voltage between positive DC and ground exceeds 65% of nominal output voltage. This alarm is used in conjunction with the Positive DC Ground Detect as a voltage divider. The relay shall be normally de-energized.

#### **9.4.4 Positive to Ground**

An indicator (Red) and alarm shall be provided when the voltage between negative DC and ground exceeds 65% of nominal output voltage. This alarm is used in conjunction with the Negative DC Ground Detect as a voltage divider. The relay shall be normally de-energized.

#### **9.4.5 Over-temperature**

An indicator (Red) and alarm shall be provided when the ambient temperature is excessive (typically >65°C) . The relay shall be normally de-energized.

#### **9.4.6 Bypass Source Low Voltage**

An indicator (Red) and alarm shall be provided when the bypass source is less than 90% of nominal. The relay shall be normally energized.

#### **9.4.7 Bypass Source High Voltage**

An indicator (Red) and alarm shall be provided when the bypass source is greater than 110% of nominal. The relay shall be normally de-energized.

#### **9.4.8 Low AC Output**

An indicator (Red) and alarm shall be provided when the AC output voltage is less than 90% of nominal. The relay shall be normally energized.

#### **9.4.9 High AC Output**

An indicator (Red) and alarm shall be provided when the AC output voltage is greater than 110% of nominal. The relay shall be normally de-energized.

#### **9.4.10 UPS Trouble (Summary)**

An indicator (Red) shall be provided. The alarm status shall activate if any of the alarm conditions specified occur. The relay shall be normally energized.

#### **9.4.11 UPS Trouble (Summary) with Audible Alarm**

An indicator (Red), alarm, and audible alarm (front-mounted buzzer) with silence switch shall be provided. The alarm status shall activate if any of the alarm conditions specified occur. The relay shall be normally energized.

#### **9.4.12 Out of Sync**

An indicator (Red) and alarm shall be provided when the inverter's internal oscillator is not in synchronization with the bypass source. The relay shall be normally energized.

#### **9.4.13 Inverter fuse Blown**

An indicator (Red) and alarm shall be provided when the inverter fuse is blown. The relay shall be normally de-energized.

#### **9.4.14 Static Switch Fuse Blown**

An indicator (Red) and alarm shall be provided when the inverter input fuse to the static switch is blown. The relay shall be normally de-energized.

#### **9.4.14 Push-To-Test Feature**

A pushbutton shall be provided to test all LEDs.

#### **9.4.15 Latching Alarm**

A latching alarm with reset shall be provided to latch alarms that occur until the reset button is pressed.

#### **9.4.16 Manual Bypass Switch Position Indicator**

Two indicators and two SPDT alarm contacts shall be provided to indicate switch position: Normal and Bypass To Load. One alarm relay is energized and the other is de-energized under normal operation.

## 9.5 Optional Serial Communications Port

When specified, an RS-232/RS-422 communications interface port shall be provided on the front panel of the UPS, available via a 9-pin D connector. Available information shall include: system status, alarms, and metering.

### 9.5.1 Communications Format

Baud Rate:	4800 bps
Format:	ASCII data bits, one stop bit
Parity:	None
Duplex:	Full
Handshaking:	Not Required

### 9.5.2 Connections

RS-232 connections shall be:

Pin 1	Power Ground
Pin 2	TXD (Transmit)
Pin 3	RXD (Receive)
Pin 4	Signal Ground

RS-422 connections shall be:

Pin 1	RXD
Pin 2	RXD
Pin 3	TXD
Pin 4	TXD
Pin 5	Signal Ground
Pin 6	INT (Interrupt)
Pin 7	INT

## 9.6 Overload Protection

The overload devices shall not be activated when the system is started under normal conditions.

### 9.6.1 Bypass Circuit Breaker

A front access molded case breaker shall be provided for Bypass disconnection and overload protection. The A.I.C. rating of the breaker shall be 10KA minimum.

### 9.6.2 Inverter Input Circuit Breaker

A molded case breaker shall be provided for DC input disconnection of both input lines and overload protection. The A.I.C. rating of the breaker shall be 10KA minimum.

### **9.6.3 Semiconductor Fuses**

The semiconductors shall be protected from cascaded failure with special fast-acting fuses.

### **9.6.4 Optional Protection**

When specified, the following **optional** circuit breakers shall be provided:

- Inverter Output (non-Automatic)
- AC Output (Static Switch Output)

## **10.0 GENERAL REQUIREMENTS**

### **10.1 System Efficiency**

The overall DC to AC efficiency shall be greater than 80% with the inverter at full rated load and nominal input voltage.

### **10.2 Audible Noise**

The audible noise generated by the unit under rated operating conditions shall not exceed 65 - 72 dBA at a distance of 1.5 meter (typical) from any side of the enclosure and 3 feet above ground. The sound levels shall be measured with the unit operating at rated load, voltage and frequency. Note: addition of a drop/drip shield may increase audible noise by 1-3 dB.

### **10.3 Cooling**

Forced-air cooling shall be provided when necessary to ensure that all components are operating at below their specified operating temperature.

### **10.4 Wiring**

Manufacturer shall utilize NEC, bulletin 70 (US National Electric Code) and NEMA-PE-1 and PE-5 wiring practices where applicable.

Printed Circuit Board control wire shall be 22 AWG UL 3266 cross-linked Polyolefin (XLPE) 300 Volts, 105°C rated.

Control wire and Power wire shall be XLPE.

Power wiring 10AWG through 4/0 AWG shall be cross-linked Polyolefin (XLPE) 300 Volts, 105°C rated.

Power wiring 262 MCM through 777 MCM shall be DLO 90°C, 600 Volt Ethylene Propylene Rubber (EPR) inner jacket, with a Hypalon outer jacket.

All wiring and bus-work shall be copper throughout the system.

### **10.5 EMI Suppression**

Electromagnetic effects shall be minimized to ensure that computer systems, or other similar electronic systems, shall neither adversely affect nor be adversely affected by the system.

### **10.6 Control Power Supply**

The control logic power supply shall incorporate a parallel redundant concept with the inverter DC input and the bypass as a dual source of logic power, to insure control power at all times.

### **10.7 Transformers**

All power transformers or chokes shall be designed using copper windings for reliability and efficiency. The insulation type shall have a temperature rating of at least 200 C (UL 1446, Class N).

An epoxy based insulating varnish shall be applied with a V P I (Vacuum Pressure Impregnation) system to insure a low temperature rise over the 30 year design life of the transformer.

### **10.8 Nameplate Markings**

The nameplate shall be located on the front inside display door and the following minimum information shall be provided on the nameplate:

- a. Solidstate Controls, Inc., Model # and Serial #
- b. Bypass AC Input Voltage, Phase and Frequency
- c. DC Input Voltage and Current
- d. Rated Output Voltage, Amps, Frequency, Power Factor, kVA and kW.

## **11.0 MECHANICAL SPECIFICATIONS**

### **11.1 Enclosure**

The enclosure shall be a NEMA-1(IP-20), free standing, with minimum 12GA framework. Door panels shall be a minimum of 14GA steel and side panels shall be a minimum of 18GA.

The enclosure shall be mounted on channels with a 3 inch lifting base open at the front and back to facilitate moving with a forklift and to provide an entrance area for air movement through the enclosure.

The enclosure shall be designed with blank plates on the sides and rear for installation against a wall. The equipment shall be designed to allow replacement or maintenance of all components from the front.

One or more hinged doors shall be provided in the front with door locks on each. Hinged panels, 36" and larger, shall be provided with a 2 point latching system for holding the panels securely. Removable covers shall be attached with machine screws.

#### **11.1.1 Drop and Drip Shields**

When required, "drop" shields, which protect the enclosure from debris and foreign objects falling into the cabinet; or "drip" shields which protect the enclosure by preventing dripping water from entering the cabinet from above, shall be provided on the top of the enclosure.

#### **11.1.2 Fungus and Moisture Proofing**

When specified, a protective coating on components inside the UPS enclosure shall be provided when the unit is installed in environments where the ambient air is extremely humid, or is heavily laden with salt content or other contaminants.

#### **11.1.3 Vermin Screens**

Vermin Screens shall be provided to prevent the entry of small animals into the inverter cabinets.

### **11.2 Ventilation**

Air inlets and outlets shall be protected by screens or perforated metal guards to prevent the entrance of a rod having a diameter of 0.5 inches or longer.

### **11.3 Cable Entry**

Cable entry shall be through the top or bottom of the cabinet. On UL units, bottom cable entry is recommended.

### **11.4 Power Connections**

The connections to the AC output or DC input shall be of the stud type and shall be sized for full load service.

Alarm connections shall be sized to allow connection of 12AWG Wire maximum. The alarm terminal boards shall be rated for 300 VAC.

### **11.5 Parts Placement**

The system shall be designed to permit front access to modules, fuses, and assemblies. Parts, test points, and terminals shall be placed so they are accessible for circuit checking, adjustment, and maintenance without removal of any adjacent assembly or component or pose a shock hazard.

### **11.6 Wire Supports**

Permanent wire supports shall be used, no adhesive backed wire supports shall be used.

### **11.7 Wire Marking**

All point-to-point wires shall be marked with a permanent marking system on both ends of each wire.

### **11.8 Component Marking**

All PCB's, indicator lights, meters, controls, semiconductors, and fuses shall be clearly marked with the component designation for ease of serviceability.

### **11.9 Personnel Safety**

The cabinet shall be constructed so that all controls, except float/equalize, are operable with the doors closed, preventing exposure to high voltage terminals. High voltage warning labels shall be visible when any of the cabinet doors are opened.

### **11.10 Painted Surfaces**

All external painted surfaces shall be ANSI 61 Gray enamel with a minimum of 2.0 mil thickness and shall be smooth with no runs, sags, or graininess. All internal mounting plates shall galvanized steel.

## **12.0 Shop Testing**

The system testing shall be in conformance with IEEE 944-1986 section 7.0, and IEC-146-4. Certified test data shall be supplied to verify test results.

The manufacturer shall have type-test data available to demonstrate system performance with switch-mode type power supplies.

## **13.0 Documentation**

13.1 Cabinet outline and interconnect drawings shall be dimensioned and scaled, and include the following information:

- 13.1.1 Location of any removable plates for Owner's conduit entry.
  - 13.1.2 Location and size of all terminal blocks for Owner's connections.
  - 13.1.3 Location and size of ventilation openings.
  - 13.1.4 Location of cabinet grounds.
  - 13.1.5 Block diagram including currents for customer cable sizing, breaker locations and sizes, and meter locations.
  - 13.1.6 Size and weight of equipment.
  - 13.1.7 Front panel identification chart.
  - 13.1.8 Nominal heat loss for the specified equipment.
- 13.2 Schematic type drawings shall include the following information:
- 13.2.1 System schematics shall include item designations for all electrical components.
  - 13.2.2 Relay contacts diagrams shall be shown in the de-energized position.
  - 13.2.3 Wire sizes and numbers shall have the same designations that appear in the equipment.

## **14.0 PREPARATION FOR SHIPMENT**

- 14.1 Preparation for shipment shall be in accordance with the manufacturer's standard shipping procedure.
- 14.2 One complete set of instruction books and "as-built" drawings shall be included with the equipment when shipped.
- 14.3 To facilitate site access, shipment of individual cabinets, rather than complete lineups, may be necessary.